

OPERATION AND INSTALLATION MANUAL
WOODFIRE CX8



Table of Contents

1. General information.....	4
2. Delivery.....	4
3. Disposal of packaging.....	5
4. Assembly instructions.....	5
5. Installation.....	5
i. Basic installation regulations and requirements.....	5
ii. The hearth and floor.....	6
iii. Combustion air supply.....	6
iv. Direct combustion air supply.....	7
v. AirSmart.....	7
vi. Minimum distance to combustible materials.....	8
vii. Heat Shielding.....	8
viii. The Chimney.....	9
6. Connecting the stove into the heating and hot water system.....	10
i. Connections.....	10
ii. Overheat safety valve.....	11
iii. Load unit or load valve.....	11
iv. Integration into the heating system.....	12
7. Advice on fitting suitable alarms.....	14
8. Operating Instructions.....	14
i. General information on operation.....	14
9. Using the stove.....	15
i. Initial commissioning.....	15
ii. First Lighting.....	15
iii. Stove controls.....	16
iv. Heating and normal burning.....	16
v. Controlling the heat output.....	17
vi. When used on a boat, never:.....	18
vii. Heating during unfavourable weather conditions.....	18
10. Fuels.....	18
i. Wood seasoning and storage.....	19
ii. Reducing particulate emissions.....	19
iii. Emptying the ashpan.....	20
11. Cleaning and care.....	20
i. Cleaning the combustion chamber and firebrick lining.....	20
ii. Stove maintenance.....	21
12. Chimney fire.....	21
13. Troubleshooting.....	22
14. General warranty conditions.....	23
15. Woodfire commissioning checklist.....	25
16. Technical Details.....	26
17. Energy Label.....	27

Congratulations on choosing a Woodfire!

Woodfire CX8 woodburning boiler stoves are highly efficient, clean burning, EcoDesign compliant, utilising the latest combustion technology to effectively heat your house and hot water.

Please read these operating instructions carefully before installing the stove to ensure that it is fitted and used safely and correctly.

In addition to the information on its installation and safe operation, this manual also contains valuable information about the care and maintenance of your stove.

This stove is designed to burn wood, and heating with sustainably sourced wood contributes less to climate change than heating with oil or gas. When the wood is sustainably sourced the logs only release as much carbon dioxide as the tree originally took in, the trees are continually being replanted and replaced, and so that CO₂ is then taken back in as part of an ongoing cycle.

1. General information

Make sure that your stove is installed by a qualified, knowledgeable and experienced installer who is registered under one of the Competent Persons schemes such as HETAS.

The cladding and window of the stove can get very hot giving a risk of burns. We therefore recommend that you install a guard for infants and elderly or infirm persons.

Never leave a burning stove unattended.

Always operate the stove with the combustion chamber door closed. The stove is provided with a self-closing combustion chamber door, so that the door only has to be opened to light, load or clean the stove.

The warranty on the stove is null and void if any structural change is made to it.

2. Delivery

As soon as it is delivered, the stove must be carefully inspected and any damage must be noted on the delivery note. Afterwards the damage must be reported immediately to the the retailer.

When transporting the stove you must ensure that only safe, strong and approved carrying methods are used. The stove may only be moved in a stable, standing position or slightly

inclined on a sack truck. A sack truck should only be used against the back of the stove. All parts of the stove must be protected against damage, moisture and rain, or other types of contamination during transport and installation.

3. Disposal of packaging

The packaging protects the stove from damage during transportation. Any cardboard packaging materials can be recycled. The wooden parts of the packaging are untreated and can be used as firewood.

4. Assembly instructions

Your stove should be installed by a qualified, knowledgeable and experienced installer who is registered under one of the Competent Persons schemes such as HETAS.

The installer must do a thorough check of the appliance to ensure that it is in full working order before it is installed.

5. Installation

i. Basic installation regulations and requirements

When installing and operating the stove, make sure that all the relevant local, national and European standards are adhered to.

The stove may only be installed in rooms suitable for such an appliance and where it can be operated safely and maintained appropriately and may not be installed in areas in which flammable or explosive substances and mixtures are processed, which could lead to an ignition or explosion.



Throughout the installation the installer must refer to Document J of the Building Regulations for detailed guidance on recommended ways of meeting the building regulation requirements.

ii. The hearth and floor

Before installing the stove, make sure that the floor on which the appliance is standing has sufficient load capacity. Pay attention to the information on the weight and, if necessary, ensure a sufficient weight distribution by utilising an appropriate hearth.

Floors made of combustible material must be protected by a layer of non-flammable material. This can be done, for example, by tiles or a plate made of glass or sheet metal at least 12mm thick. The floor and hearth must also be strong enough to take the weight of the stove, and be completely level and stable. Please also observe the necessary measures for the fire protection of the floor. Further details can be found in Building Regulations Document J.



Please also refer to “Firepower Hearth Guidance” which can be found on the www.firepower.co.uk website. This gives recommendations for instances where we recommend that the size of the hearth is increased over and above the minimum sizes given in the building regulations, and also contains some suggestions for how you can make a feature of the hearth.

iii. Combustion air supply

The stove needs sufficient combustion air. This can be drawn from the installation room, which must have a suitable fresh air supply from the outside.

Document J of the Building Regulations provides guidance, including information on the minimum area of ventilation that must be provided to the room. Care and consideration should be given to whether there are any ventilation or extraction systems in the house and when a draught test or smoke spillage test is done these should be switched on so that the “worst case” is tested for. The installer should refer to the HETAS technical notes and guidance on ventilation.

Relatively little air is required for combustion when the door of the stove is closed. It is when the door is opened that air rushes up the chimney and there must be a matching supply of air to the room, otherwise smoke is liable to escape into the room.

When installing a stove into a modern well-sealed house, or one which has been extensively upgraded with well-sealed windows and doors, it is likely that there will not be enough fresh air supply to the room when the door of the stove is opened. It is also likely that the homeowner will not want to install a permanent vent to the room because that creates a hole in their well-sealed house.

Ventilation systems, such as extractor fans, in the same room as the stove should be avoided where possible, and can adversely affect the function of the stove.

The Passiv stove can be connected to a direct air supply duct and, if the intention is to not install a permanently open vent to the room, or to install an AirSmart system in its place, then

the installer must follow the procedure in Hetas Technical Note TN_0020 to confirm that the supply of air will be sufficient.



Please also refer to our “Firepower Direct Air Guidance” document which can be found on the www.firepower.co.uk website. This gives further consideration as well as mandatory duct sizing information if a direct air supply duct is being connected to the stove.

iv. Direct combustion air supply

The spigot for connecting to a direct combustion air supply is on the back of the stove (Ø 100mm). Any ducting used to bring air from the outside must be at least the diameter of the spigot and then designed and sized in accordance with “Firepower Direct Air Guidance”.

Unless appropriate safety devices are employed to ensure that the stove can only be run with the air supply open, all direct air ducts should be fixed open.



The installer must refer to the “Firepower Direct Air Guidance” document which can be found on the www.firepower.co.uk website. This gives mandatory duct sizing information and design considerations.

v. AirSmart



Connecting an AirSmart controller and vent is a way to avoid potential ventilation problems. A door sensor is fitted to the stove and whenever the door is opened the controller opens a sealed vent to the room to supply extra fresh air. If there is a powercut then the vent is also opened as an additional safety feature. The AirSmart controller can be a stand-alone unit, or combined with a full automated stove controller (as pictured) which also automatically regulates the burning rate of the stove, and adds in additional safety features.

If the intention is to not install a permanently open vent to the room, or to install an AirSmart system in its place, then the installer must follow the procedure in Hetas Technical Note TN_0020 to confirm that the supply of air will be sufficient.

vi. Minimum distance to combustible materials

- A 1000 mm From the front of the stove
- B 100 mm Behind the stove
- C 100 mm To each side of the stove

When the stove is installed, all fire protection regulations and the minimum distances specified must be kept to.

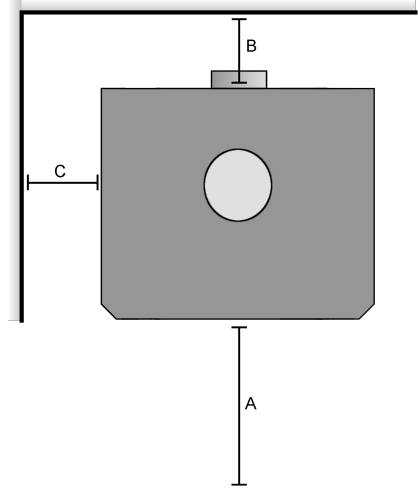

vii. Heat Shielding

It is also possible to heat shield combustible materials if the stove must be installed at a closer distance than specified here. For heat shielding refer to the guidance detailed below.



For further information on heat-shielding please refer to the “Firepower Heat Shielding Guide” which can be found on the downloads section of the www.firepower.co.uk website. This gives in depth guidance on heat-shielding combustible materials using metal or Thermalux sheets.

viii. The Chimney



All flue components used must be suitable for solid fuel fires, rated to T400°C, and comply with the relevant regulations regarding their construction and installation and all manufacturers' instructions must be followed.

Particular attention must be made in regard to the distance to combustible materials.

The chamber should be closed off above the stove with a concrete slab, lintels or fireproof stud work.

The following chimney designs are possible:

Brick or block wall chimney: This should be lined with pumice liners (not clay liners) of the correct diameter and the starter block should be set on the slab. The stove is then connected to the starter block with an adjustable length of single skin flue.

Twin wall stainless steel insulated chimney: The hole in the top of the chamber should be a good fit around the pipe using a fire stop plate.

Stainless steel flexible liner (Class 1 - suitable for solid fuel, either 316 or 904 grade). This is used to re-line an existing Class 1 masonry chimney: The liner should connect to the appliance via a length of rigid flue at least 500mm long. The liner should be firmly fixed to the chimney wall with a bottom support bracket or, if that isn't possible, then every pipe connection, including the connection to the stove, should be secured with at least two stainless steel self-tapping screws. The flexible liner should be insulated. The chimney should be fitted with a cowl or appropriate chimney pot to prevent rain entry.

Offsets used in the flue run can adversely affect the chimney's performance. Any bends used should be the minimum offset possible from the vertical (maximum permissible is 45°) and no more than four offsets should be used in any one system. If bends are used then it may be necessary to increase the height of the chimney to counteract any detrimental effect they may have on the chimney draught.

The chimney must be able to maintain a draught of 12 Pascal's.

Flue termination heights must comply with the requirements of Document J of the Building Regulations.

Adequate provision must be made so that all internal parts of the chimney can be cleaned.

This stove is not suitable for use on a shared chimney.

Recommendations:

- Working level of chimney: min. 5 meters
- Maximum diameter of flue 160 mm
- Any existing chimney should be examined by an expert

6. Connecting the stove into the heating and hot water system

Connecting the stove to a central heating and hot water system must be carried out by a suitably qualified and experienced heating engineer. All safety requirements must be adhered to and any safety components that need to be checked or serviced must be made accessible. All protective caps on the connections must be removed during assembly. All plumbing connections must be connected according to their intended use.

i. Connections

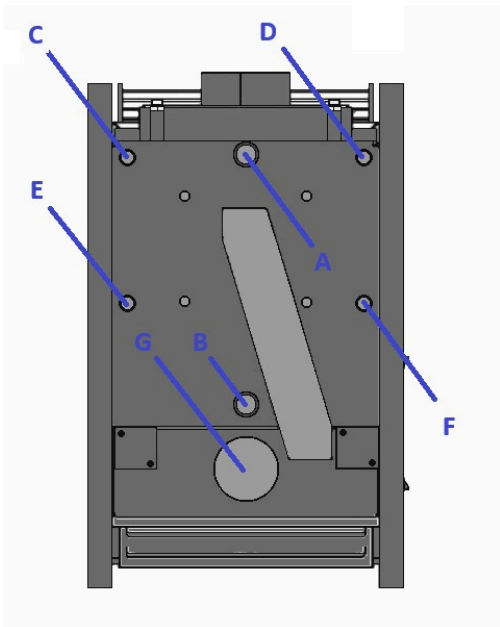

A	1" BSPF	Primary flow
B	1" BSPF	Primary return
C	1/2" BSPF	Thermistor port
D	1/2" BSPF	Spare thermostat port – blank off if not used.
E	1/2" BSPM	Quench coil connection
F	1/2" BSPM	Quench coil connection
G	100 mm	Direct air spigot

A pressure relief valve with a maximum response pressure of 3.0 bar must be installed in the system. There must be no isolation valve between the boiler and the safety valve.

Bleed and refill the heating system and heat exchanger before the initial start-up when air locks are detected.

All necessary safety devices must be installed in such a way that their safe operation is ensured. Carefully follow the installation and operating instructions of these safety components.

ii. Overheat safety valve

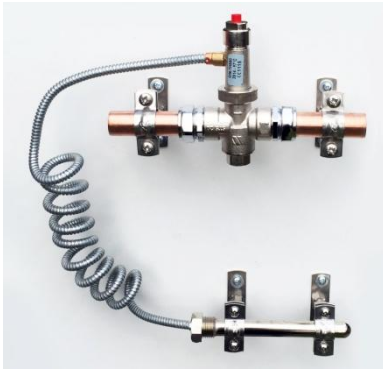

The stove must have a suitable overheat safety valve installed and this would commonly be supplied along with the stove. This consists of a temperature probe which is installed into a tapping on the stove boiler which opens a valve if the boiler overheats. The valve allows mains cold water to run through a heat exchange coil inside the boiler. This cools down the boiler and the resultant hot water is then discharged outside. Care must be taken that the discharge cannot cause harm and so should be treated in a similar way to the discharge of a pressure or

temperature relief valve.

Before the system is commissioned it should be checked for leaks and to ensure that it is functioning correctly.

A water pressure of at least 2 bar and a minimum throughput of 900 l / h must be provided at the cold water inlet of the overheat safety valve. This supply line must not be capable of being shut off and it must maintain a constant water pressure.

The installation of the overheat safety valve must be designed in such a way that it is possible to access it to test that it works. This should be at least yearly and is done by pressing the red button down to verify that cold water flows through the boiler coil and outside to waste.

Before connecting the cold water pipe to the stove, the pipe must be flushed to prevent the introduction of impurities into the opening and closing mechanism of the overheat safety device.

iii. Load unit or load valve



The stove must be installed with a load unit or load valve to ensure that the return temperature is always above 55°. The circulation pump should be controlled by a flue thermostat or via an automated stove controller. This will inhibit the formation of tar on the boiler and so extend cleaning intervals, it will protect the boiler against condensation, and it will improve the efficiency and effectiveness of the combustion by getting the firechamber up to running temperature fast, and then maintaining that temperature.

If not fitted then the warranty reduces to 1 year. See the Warranty section for more details.

iv. Integration into the heating system

The boiler stove should only be integrated into a heating system after the complete system has been designed by an appropriately qualified and experienced heating engineer.

All the relevant safety standards must be complied with.

The intended heating system can be laid out as an open or closed heating system. In any case sufficient overheating safeguards must be installed.

If installed on a closed (pressurised) system, a pressure relief valve should be installed in the water circuit as close as practicable to the appliance and in a position where it would vent safely, along with the overheat safety valve.

If installed on an open vented system, the feed and expansion tank must be manufactured to BS 4215, and be designed to withstand the 500-hour boil test without leaking or collapsing. It should be installed as high as possible, in the highest part of the circuit and as near as possible to the boiler.

A heat sink radiator can be fitted in addition to the overheat safety valve if desired.

The water in the central heating system should contain suitable antifreeze to give frost protection. After a period of inactivity, on no account should the appliance be lit until it is ensured that there is a free flow of water through the central heating and hot water systems. The use of a return-flow-elevation/load unit (such as an LK 810 ThermoMat Eco load unit) with an adjusted minimum temperature of 60°C is essential to ensure the stove burns cleanly and efficiently. The maximum operating temperature is 90°C. The maximum operating pressure may not exceed 2.5 bar.

A minimum pipe size of 28 mm should be employed up to and back from the load unit. If there is a heat leak radiator in the circuit then a minimum pipe size of 28mm should be used on the flow and return from that radiator to facilitate thermosyphoning.

Pay attention to a correct design of all components in the heating system.

The operator must be instructed in the operation, functioning and maintenance of the entire system including any additional specialist components.

To realise the full potential of a heating and hot water system run by a Woodfire boiler stove it is important to have an accumulator (buffer) tank in the system.

At the lowest points of the heating system an outlet valve needs to be installed.

The figure on the next page is a typical plumbing schematic showing the boiler stove connected to a thermal store. The positioning of the pipes for the heat leak radiator (if fitted) around the load unit is very important. In the LK 810 ThermoMat range, the gravity circuit flap grub screw should be removed to allow circulation around the heat leak radiator (if fitted) in the event of power failure.

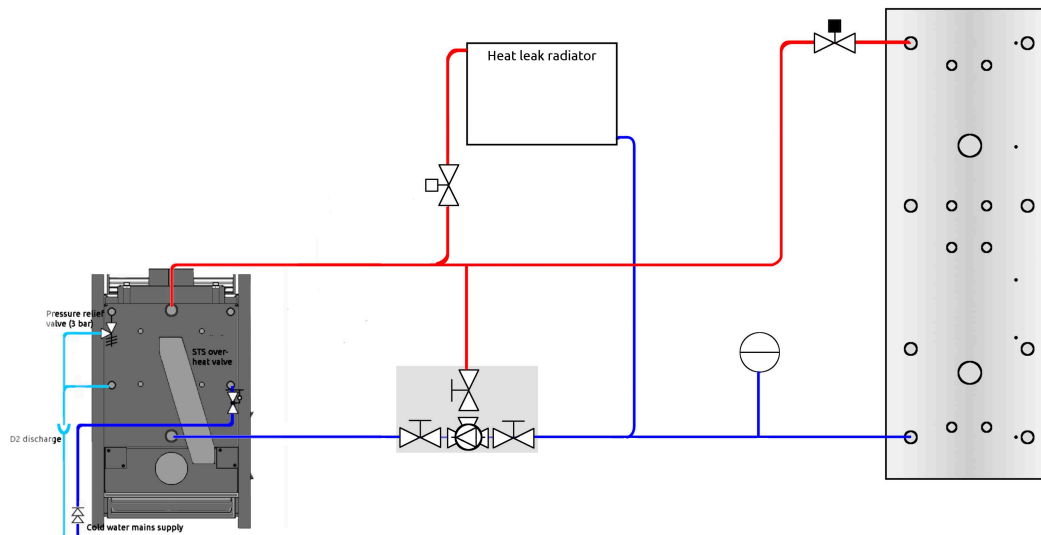

Below is a typical schematic showing connection to an open vented system with a thermal store. Again care and attention should be paid to how, and where, the heat leak radiator, and fill and expansion tank are connected.

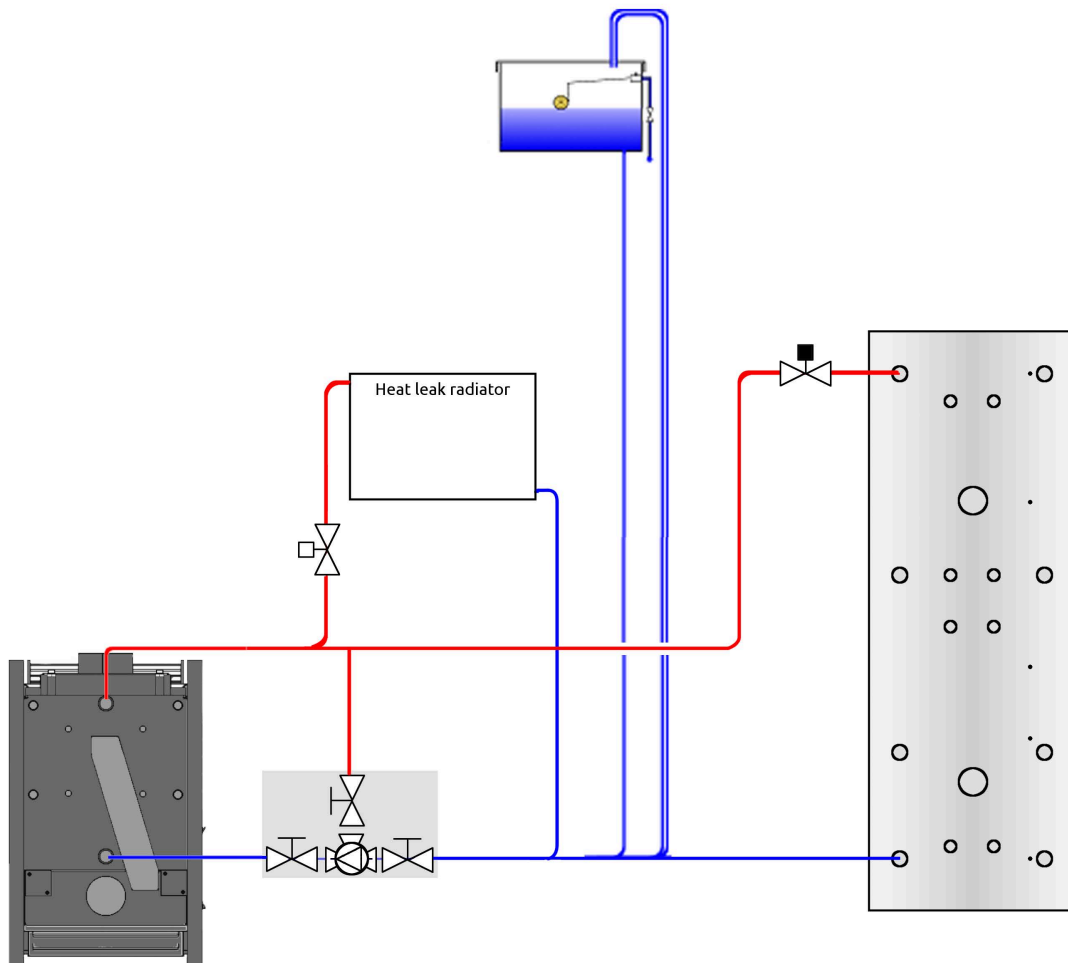

7. Advice on fitting suitable alarms

At least one suitable and effective smoke alarm should be fitted in a suitable location. Alarms should be mounted on the ceiling at least 300mm from any walls and within 5 meters of the protected area. This may mean installing more than one alarm, and it is recommended to choose units that can be linked together. The smoke alarm should be capable of waking any occupants sleeping. The alarm should be tested with this in mind before the final fixing is made. The smoke alarm should be of the optical or photo electrical type since this is particularly sensitive to dense smoke such as produced from a smouldering fire. The smoke alarm should be fitted with an extra-long life battery and have a hush button to allow for temporary deactivation. This should be tested routinely.

A carbon monoxide alarm certified to BS EN 50291 should also be fitted and, on boats, it should be suitable for marine use.

8. Operating Instructions

Before starting to use the stove please read these installation and operating instructions carefully. Please remove any loose items and packaging remnants (except the combustion chamber lining) from the combustion chamber and the ash pan.

Your installer should show you the function and operation of the stove during the handover and ensure that you fully understand the controls and how the stove should be used.

When operating this stove you must observe local and national standards and regulations.

i. General information on operation

- Risk of burns. Soon after the stove is lit, the window and exposed parts of the stove become very hot. Infants and infirm persons should be kept away from the stove. We recommend installing a guard and if there are children in the home then it is a building regulation requirement that fixings for a fireguard are installed by the installer. Pay attention at all times to the potential dangers of a woodburning stove.
- During the operation of the stove do not put objects on the stove or lean anything against the stove. Never place objects or laundry on the stove to dry. Drying racks are only to be set up outside the immediate radiation area of the stove.
- Combustion in the stove releases thermal energy that causes the stove surfaces and components to become hot. Do not touch the door, handles, glass or flue pipes, etc. without a suitable protective glove when the stove is in operation.
- The enclosed protective glove serves only as heat protection when operating the stove during or shortly after firing. The glove is not fireproof and so you should not, for example, attempt to pick up burning logs with it or put it into direct contact with flames.

- Only operate the stove with the combustion chamber door closed. It must always be kept closed when the stove is cold. The door is only opened for lighting, refuelling or cleaning.
- The stove must not be altered structurally or technically. In particular, no installation parts may be placed in the combustion chamber or in the exhaust or combustion air ducts, unless these are expressly approved by Woodfire. Any unauthorised conversion of the stove will void the warranty.

9. Using the stove

i. Initial commissioning

The installation, assembly and initial commissioning of the stove must be carried out by a suitably qualified and knowledgeable engineer. The owner or operator of the stove must be made familiar with the operation of the appliance and given a certificate of installation, and the commissioning sheet at the back of this manual should be completed.

Before commissioning, make sure that all necessary components and safety components are installed and functioning. The plumbing connections and components must be filled and vented (if necessary several times). Check all plumbing connections for leaks after filling. Check the functionality of the stove. Never use the stove without it being connected to the heating system as this can lead to severe damage and leakage. There is no warranty for damages caused by the use of the stove without it being filled with water and properly connected to a functioning heating system.

ii. First Lighting

Light only a small fire when the stove is first put into operation. The combustion chamber lining can still contain residual moisture and could form cracks if the initial heat is too high. Increase the heat output by 30% over the next three firings so that the heat-resistant paint can cure. Until fully cured, the paint can be soft. Please avoid any contact with the painted surfaces of the stove until the paint has fully hardened.

It may happen that during the paint curing process, an unpleasant odour with a slight smoke is formed. This is normal - please open the windows and doors during this process to ensure good room ventilation.

During the first operation, condensation water may escape from the combustion chamber lining on the bottom of the stove. This is residual moisture from the production process of the firebricks.

iii. Stove controls

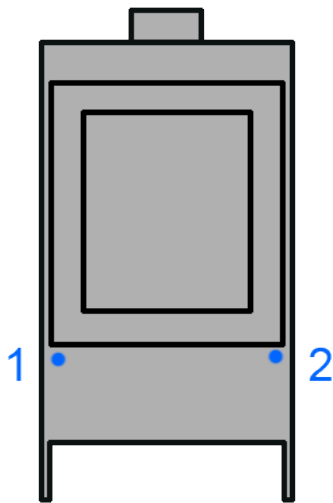

- 1 Primary air control
- 2 Secondary & tertiary air control

Both controls:
Pull out to close
Push in to open

iv. Heating and normal burning

Please observe the following instructions when starting the stove:

- The stove may only be operated with the combustion chamber lining in place.
- Before lighting always check that the stove has a sufficient supply of combustion air.
- Full open the air controls by pushing both in, and open the firebox door.
- Do not use paper, petrol, oil, spirit, or other flammable liquids to start the fire.
- If the chimney draft is very strong, the wood can burn too fast. Regulate the air supply with the air lever for a steady and economical burn. Do not let it burn without a good flame, or "turn it down for the night" as attempting to run it too slowly will lead to a smoky, dirty burn and black glass.
- Remove enough ash from the grate to let air through but leave some of the ash there. (beware the ash may still be hot even hours after the stove has gone out). Dispose of hot ash safely.
- Put 2 - 3 medium sized logs in the centre of the firebox, put some smaller logs on top of them and then kindling on top. Finally put 2-3 firelighters on top of the kindling.
- Light the firelighters and close the door.

- When all the fuel is properly burning, and the working temperature of the stove is achieved (after approximately 15-30 minutes), gradually move the primary air regulator backwards, but ensure that there is still a visible flame.
- When the stove and flue are fully up to temperature, and the fire burning well, then the primary regulator can be completely closed and the burning of the stove regulated using the secondary air control.
- The door should only be opened again when the fuel has burned down and you want to put new fuel in. When opening the door, ensure that the flue damper is fully open. Re-fuelling must be carried out onto a sufficient quantity of glowing embers so that the new fuel will ignite in a reasonable period. If there are too few embers in the fire bed, add suitable kindling to prevent excessive smoke.
- When refuelling it is good practice to put in a couple of smaller bits first as the larger logs then light faster, so producing less smoke. When adding wood, the primary air control and flue damper must always be open, and left open until the new logs have caught fire. At that point close the primary control and use the secondary air control to adjust the combustion.
- Use the amount of fuel you place in the stove to regulate the temperature.
- To burn at the nominal output, the stove requires refuelling every 45-50mins with approximately 1kg of wood logs.
- **THE STOVE SHOULD NEVER BE FILLED EXCESSIVELY. EXCESSIVE AMOUNTS OF WOOD OR AIR FOR COMBUSTION CAN CAUSE OVERHEATING AND DAMAGE THE STOVE.**

v. Controlling the heat output

The heat output from a stove is controlled by the amount of fuel that is put into it, NOT by opening or closing the air control.

The air control lever is there to enable the user to establish the optimum burn.

Closing the air control lever too much can lead to an incomplete combustion. In addition to wasting fuel and creating unnecessary pollution it also risks an explosive ignition of the flue gases.

Opening the air control lever too much can result in the stove overheating and can risk damaging the appliance.

The performance of your stove is influenced by the chimney draught. Depending on the length and cross section of the chimney, as well as the weather or wind, the chimney draught changes. The control lever allows small adjustments to compensate for a stronger or weaker draught.

If an AirSmart controller is fitted then many aspects of the proper control of the burn rate of the stove are automated.

vi. When used on a boat, never:

- leave the craft unattended, or travel through tunnels, when the solid fuel appliance is in use without checking that the appliance has not been over-fuelled and ensuring that the controls are appropriately set to prevent over-firing
- Operate the appliance the appliance with any door open, except for refuelling and removal of ashes, as this may over-fire the appliance, with consequential damage to the appliance and danger of boat fire
- Block or restrict the ventilators to the cabin
- Fill any petrol tank on or near the craft when a solid fuel appliance is in use

vii. Heating during unfavourable weather conditions

At higher outside temperatures (above 15 ° C) or in adverse weather conditions (gusting winds, etc.), the chimney draft can be negatively affected, which means that existing flue gases are not completely removed. In this situation the stove should only be loaded with a small amount of fuel and the air set to the fully open position. Once the stove is pulling strongly again then the air controls can used as normal.

10. Fuels

This stove is designed to burn **wood or wood briquettes only**. The wood must not exceed a moisture content of 20% measured on a wet basis (or 25% if using a moisture meter that measures on a dry basis). Look out for the Woodsure Ready to Burn logo which verifies that the wood is dry and ready to be used.

Logs should be, approximately, no more than 330mm long and 100mm in diameter.

Only the approved fuels may be used and therefore the burning of these materials is not permitted:

- Painted or plastic coated wood
- Particle board or wood treated with wood preservative

- Wood from europallets
- Waste, household or clothing waste
- Paper, paper briquettes, cardboard
- Coal, coal briquettes, lignite
- Plastics and foams.
- Solid and liquid non-wood materials

Burning materials other than the permitted fuels may result in the formation of harmful fumes, damage to the stove and uncontrolled burns. Damages caused by the use of unauthorized fuels are not covered by the guarantee.

i. Wood seasoning and storage

In order to dry or “season” freshly cut firewood should be stored in a well-ventilated area protected from moisture for approximately 2-3 years. Store your wood split so that the release of moisture is quicker. Do not stack the logs too tight to ensure the best possible air circulation. Firewood should not be stored directly on the ground. Do not store your firewood under tarpaulins, plastic sheeting or in poorly ventilated locations.

Firewood that is already seasoned or dry should be stored in a suitable dry location.

When buying firewood look for the Woodsure “Ready to Burn” marking and logo.

ii. Reducing particulate emissions

Sustainably managed and sourced wood has significantly lower carbon emissions than oil or gas. On the other hand particulate emissions have a harmful effect on health, and there many ways in which you can reduce them:

- Only burn dry, well seasoned wood (with a moisture content of 20% or less measured on a ‘wet basis’, or 25% or less measured on a ‘dry basis’). Look out for the WoodSure “Ready to Burn” logo.
- Light your stove using the “upside down method” described in this manual where you start with a couple of bigger logs, then the kindling, then the firelighters. This gets the firebox up to temperature faster and has been shown to result in lower particulate emissions in lab tests.
- Adjust the amount of wood you put into the fire based on how much heat you actually need. Do not fill the fire chamber up and then try to control the heat output by turning down the air controls.
- Make sure that the fire is burning well. Some signs of this are that the ash should be white. Black charcoal in the ash indicates an incomplete burn. The combustion

chamber lining of the stove should be bright after firing and not sooty black. You should see good flames in the firebox at all times, without wisps of smoke. Incomplete combustion is generally always to do with an improper mix of three things: temperature, air, and fuel.

- Never “turn it down for the night”.
- Your stove must not be used to burn waste.

iii. Emptying the ashpan

It is recommended to clean out the ash every day.

Be careful that too much ash is not accumulated otherwise there is the danger that, if the ash reaches up to the grate, it will not cool sufficiently and may get damaged. However some ash acts as an insulating layer at the base of the stove and in no way harms the operation of the stove as long as it is not blocking the grate.

To access the ash draw, pull the top of the grill under the air control levers to hinge this grill down. The drawer is behind. Turn the lever and pull the drawer out towards you (beware the ash may still be hot even hours after the stove has gone out). Dispose of hot ash safely.

Before emptying the ashpan, check if there are any embers left in the ashtray.

Even though the ash is cold from the outside, it is possible that there are embers within the ash which can lead to a fire in the waste bin, and can lead to carbon monoxide emissions if left inside. It can make sense to empty the ashes into a suitable metal outside, kept well away from anything flammable, so that any hot ashes can safely cool before being disposed of.

11. Cleaning and care

Clean your stove only when it is cold. Use work clothing and cover the area in front of your stove with a protective sheet. Make sure that any disassembled parts are correctly positioned back in the stove after cleaning.

i. Cleaning the combustion chamber and firebrick lining

For cleaning steel parts use non-abrasive detergents and a soft rag and, after cleaning, clean it damp rag to avoid the deposit of detergent which can damage material. Dry off the stove afterwards

After washing, wipe over with clean water and if there are condensates, do not wait until they are dried, rather wipe them immediately.

Attention, the stove paint only achieves its ultimate strength after reaching its rated temperature a few times. To avoid damaging the paint, it is recommended to clean the stove surface only when the paint achieves its ultimate hardness.

Cleaning the glass should be done when the stove is cold, using normal detergent for washing the glass. In the case of solid deposits that should be removed, we recommend using a stove glass cleaner.

It is important to have the chimney regularly checked and cleaned by a qualified chimney sweep.

The combustion chamber, baffle and heat exchangers above the combustion chamber must be examined for deposits at regular intervals and, if necessary, cleaned. Use a hand brush or an ash vacuum cleaner to remove the debris. Check for blockages inside the stove and chimney at the beginning of the heating season, clean the stove and sweep the chimney once in the middle of the season, and then clean and sweep at the end of the season. Heavy use of the stove may require more frequent chimney sweeping and cleaning in the stove. Before each heating season check the chimney and flue for any blockages. The stove should be serviced annually by a specialist.

The heat exchanger tubes will also need cleaning and can be reached by taking the baffle deflector plate out of the stove. Make sure it is re-positioned correctly.

A woodburning stove burns best with an ash bed. It is therefore not necessary to remove all the ash from the base of stove after each burn – but the grate and ashpan should be clear to allow air to flow to the fire from below, and to stop the grate becoming too hot.

The viewing window is easiest to clean with a commercially available glass cleaner, then wipe it with a dry cloth. Make sure that the fire rope does not get wet and that no scratches are made in the glass. Any damage due to improper cleaning is not covered by the warranty.

ii. Stove maintenance

Periodically check that the door seals are in good condition and replace the fire rope if it is worn or damaged. The thermal safety devices (overheat safety valve, pressure relief valve, etc.) must be checked by a qualified engineer before the start of the heating season. Only use spare parts authorised by your heating engineer.

12. Chimney fire

A chimney fire can be caused by regularly burning unseasoned wood, persistently slow burning for long periods, not having the chimney swept regularly or burning unsuitable fuels.

In the event of a chimney fire close the doors and air inlet of your stove and call the fire brigade.

After a chimney fire, the chimney must be inspected by a qualified engineer before it is used again.

13. Troubleshooting

Symptom	Cause and Solution
<p>The stove glass is black and sooty. The glass should be wiped clean every few days but if it is getting excessively black then there are a number of probably causes.</p>	<ul style="list-style-type: none"> The firewood is too wet. Only use wood with a moisture content of 20% or less. The firebox is being overloaded with too much wood. This will cause an excess of moisture in the firebox leading to blacking of the glass. Too little wood is being used from the start or the air lever has been closed down too quickly after the fire has been lit. This prevents the stove and chimney coming up to the proper working temperature and causes an incomplete combustion. The chimney has insufficient draw due to it being too short or terminating in the wrong place. The fire is receiving insufficient combustion air caused by a blockage or an undersized combustion air duct.
<p>Fire is difficult to start</p>	<ul style="list-style-type: none"> The moisture content of the wood is too high. Only use wood with a moisture content of 20% or less. The logs are too thick. Kindling and thinner split logs should be used to start the fire. Bigger logs should only be used once the stove is hot. The fire is receiving insufficient air. Is the supply air control set correctly and are the combustion air ducts free of obstructions? Are the chimney and connectors free of obstructions?
<p>When adding wood, smoke is spilled from the door opening.</p>	<ul style="list-style-type: none"> Is the wood dry enough? Has sufficient wood burnt to bring the stove and chimney to operating temperature? Is the chimney correctly sized? Is the chimney suffering from downdraft (ie puffing smoke during certain weather conditions). Check that the chimney terminates sufficiently far away from trees or nearby buildings. Fit an anti-downdraft cowl. Has the stove door been opened too fast?
<p>Too fast burning / wood consumption too high</p>	<ul style="list-style-type: none"> Were adequately sized logs used? Has too much wood been loaded into the firebox Was the air supply control set correctly and the supply of combustion air reduced?
<p>The overheat safety valve is constantly running water</p>	<ul style="list-style-type: none"> Your central heating system may not need any more heat. Turn the air controls of the stove down. Do not load more wood into the stove. The thermal store may have reached its maximum temperature but the stove is still burning. Turn down the air controls on the stove. Turn on your central heating so that that it uses up some heat from your thermal store. Check the function and setting of the pump control and the load

valve.

- Is the circulation pump running?
- Vent the boiler and check the system pressure.
- The valve may have become stuck or there may be detritus inside it. There is a red button on the valve – when pressed down this can be used to test that it works. Press down a couple of times on this red button and this may re-seat the valve.

Noises in the heat exchanger / air in the heating system

- 0

The overheat safety valve drain is dripping

- The valve may have become stuck or there may be detritus inside it. There is a red button on the valve – when pressed down this can be used to test that it works. Press down a couple of times on this red button and this may re-seat the valve.
- Check the seat of the connection seals and the piston (see instructions for the overheat safety valve).
- Add a filter in the cold water inlet in front of the overheat safety valve.

The radiators stay cold

- The heating system takes time to pass the heat to the radiators.
- Has the heating system been balanced?
- Check that the circulation pump is working.

The combustion chamber lining is black

- Check the combustion chamber, the baffle deflectors and the chimney for blockages.
- The moisture content of the wood is too high. Only use wood with a moisture content of 20% or less.
- Check that the stove is receiving sufficient combustion air.

14. General warranty conditions

The warranty cover is effective from when the unit is handed over to the buyer.

In case the commissioning does not take place within 3 months from the date of purchase then the warranty period starts on the day of purchase of the product, which must be demonstrated by proof of purchase such as a sales receipt or paid invoice from the seller.

Woodfire declines all liability for any accidents due to failure to observe the specifications contained in the use and maintenance manual accompanying the device. Furthermore, Woodfire declines all liability deriving from improper use of the product by the user (including heat-shock, overload or misuse of the firebox), unauthorised modifications and/or repairs, and the use of non-original spare parts or spare parts not designed for use on this model.

The duration of the warranty is three years on the firebox house, grate, throat baffle, moving parts (hinges, handle, and fittings).

This reduces to 1 year if a load unit or load valve is not fitted.

The warranty does not cover combustion chamber linings, fire ropes, grates or viewing windows unless, in the first six months, it can be shown that there has been a manufacturing fault that caused the defect.

The warranty period and the scope of the warranty are granted under these terms and conditions beyond the statutory warranty, which remains unaffected.

The guarantee is not valid if there has been:

- Non-compliance with the assembly and operating instructions or there have been technical modifications to the stove by non-company personnel
- Improper handling, improper use, incorrect installation or incorrect connection of the stove to the heating system
- The stove has been lit when not connected to a heating system
- Missing or faulty maintenance to the stove or chimney
- Improper transport or improper storage
- Overheating, thermal overload and resulting deformation or discoloration of the stove or the viewing window
- Normal wear and tear of the stove.

Regardless of the statutory warranty, which has priority over the warranty within the statutory warranty periods, any defective parts that are demonstrably based on a material defect or manufacturer's defect are replaced free of charge within the scope of the stated warranty conditions.

Woodfire reserves the right to either eliminate the defect or replace the appliance. The warranty covers supplying a replacement part but does not cover any labour associated with fitting the part or any further damages or costs related to the defect nor costs arising from de-installation or re-installation of the appliance.

If parts are replaced then the warranty period will be extended for the replaced part. Only spare parts approved by Woodfire may be used.

15. Woodfire commissioning checklist

General Information

Stove purchased from.

Tel: _____

Email: _____

Installed by.

Tel: _____

Email: _____

Installation date.

0

Notice plate and accompanying checklist completed.

Notice plate location.

0

Confirm that relevant local and national regulations have been followed, including, in the UK, Document J of the Building regulations.

Water safety

Pressure release valve fitted and tested

If the system is pressurised then please confirm that an expansion vessel of the right volume has been fitted, and precharged to the correct pressure.

Load unit fitted and verified to be working

If a direct air duct has been used then the guidelines in the Firepower Direct Air Duct Guidance has been followed.

The system has been commissioned including running the boiler through a complete burn cycle.

Handover

Handover: user shown how to use the appliance and has the necessary documentation.

Handover: the importance of using only well seasoned wood has been explained.

Handover: safety issues and required maintenance explained to the user.

Signed

Commissioning engineer's signature* _____

**By signing this you confirm that all commissioning checks above have passed, and that operation and maintenance of the appliance have been explained to the customer in full in line with this user manual.*

16. Technical Details

	CX8	CXC8
Output	8 kW	8 kW
Output to water	5.4 kW	5.4 kW
Output to the room	2.6 kW	2.6 kW
Efficiency	76 %	76 %
Weight	130 kg	130 kg
Operating pressure	2.5 bar	2.5 bar
Minimum chimney draft	12 Pa	12 Pa
Combustion chamber lining	Vermiculite	Vermiculite
Fuel	Wood & wood briquettes	Wood & wood briquettes
Test Standard	EN 13240	EN 13240
PM	24 mg/nM ³	24 mg/nM ³
Rating	A	A
External air supply diameter	100 mm	100 mm
Flue diameter	150 mm	150 mm
Size, H, W, D	870, 520, 440 mm	988, 520, 440 mm
Max log length	330 mm	330 mm

17. Energy Label

 **ENERGY**

Woodfire CX8, CXC8

A++
A+
A
B
C
D
E
F
G

A

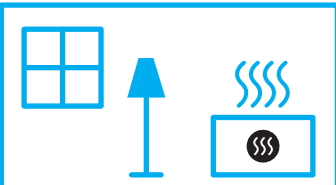
 **2.6**
kW

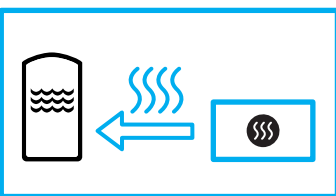
 **5.4**
kW

2015/1186



Distributed by Firepower
Dunkeswell Business Park,
Dunkeswell, Devon
EX14 4RD, UK

www.firepower.co.uk

+44(0) 800 246 1260